



US 20140159021A1

(19) **United States**

(12) **Patent Application Publication**
SONG et al.

(10) **Pub. No.: US 2014/0159021 A1**
(43) **Pub. Date: Jun. 12, 2014**

(54) **ARRAY SUBSTRATE, METHOD FOR FABRICATING THE SAME, AND OLED DISPLAY DEVICE**

(52) **U.S. Cl.**
CPC *H01L 27/322* (2013.01)
USPC *257/40; 438/29*

(71) Applicant: **BOE TECHNOLOGY GROUP CO., LTD.**, Beijing (CN)

(57) **ABSTRACT**

(72) Inventors: **Youngsuk SONG**, Beijing (CN); **Seongyeol Yoo**, Beijing (CN); **Seungjin Choi**, Beijing (CN); **Heecheol Kim**, Beijing (CN)

This invention provides an array substrate, a method for fabricating the same, and an OLED display device. Each pixel unit of the array substrate comprises: a TFT drive layer; an OLED further away from the substrate than the TFT drive layer and driven by it, the OLED sequentially comprises a first electrode, a light emitting layer, a second electrode, wherein the first electrode is transparent, and the second electrode is a transmissive layer, or the second electrode is transparent and has a transmissive layer disposed thereon; a reflection layer disposed between the TFT drive layer and the OLED and forming a microcavity structure with the transmissive layer, and a reflective surface of the reflection layer has a concave-convex or corrugated structure disposed thereon for causing diffuse reflection of light; and a color filter film disposed between the reflection layer and the OLED and located in the microcavity structure.

(21) Appl. No.: **14/105,141**

(22) Filed: **Dec. 12, 2013**

(30) **Foreign Application Priority Data**

Dec. 12, 2012 (CN) 201210536682.9

Publication Classification

(51) **Int. Cl.**
H01L 27/32 (2006.01)

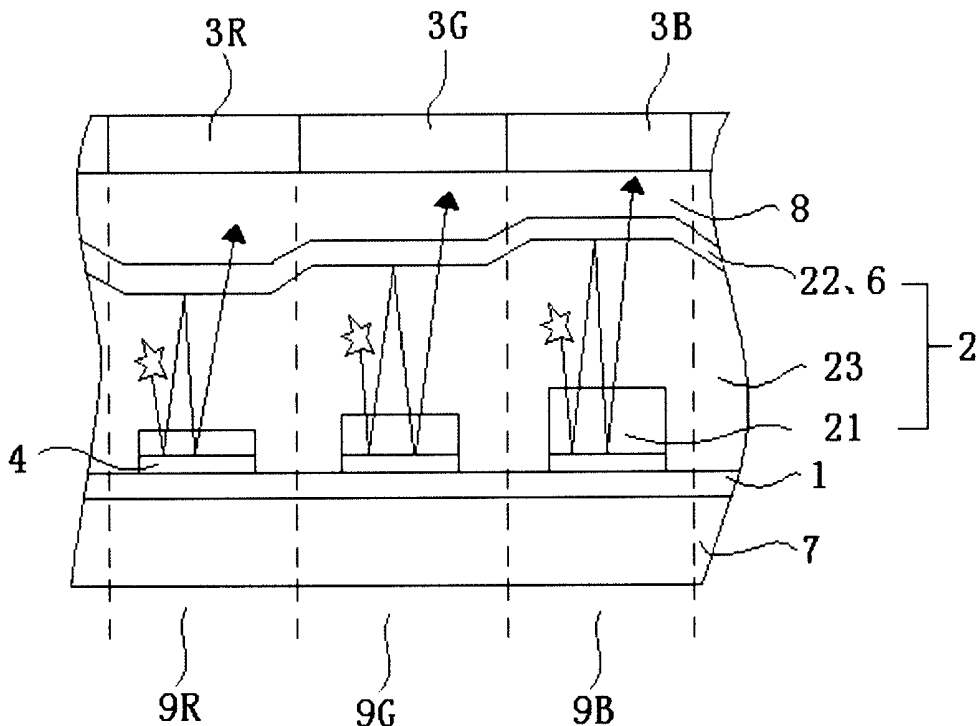

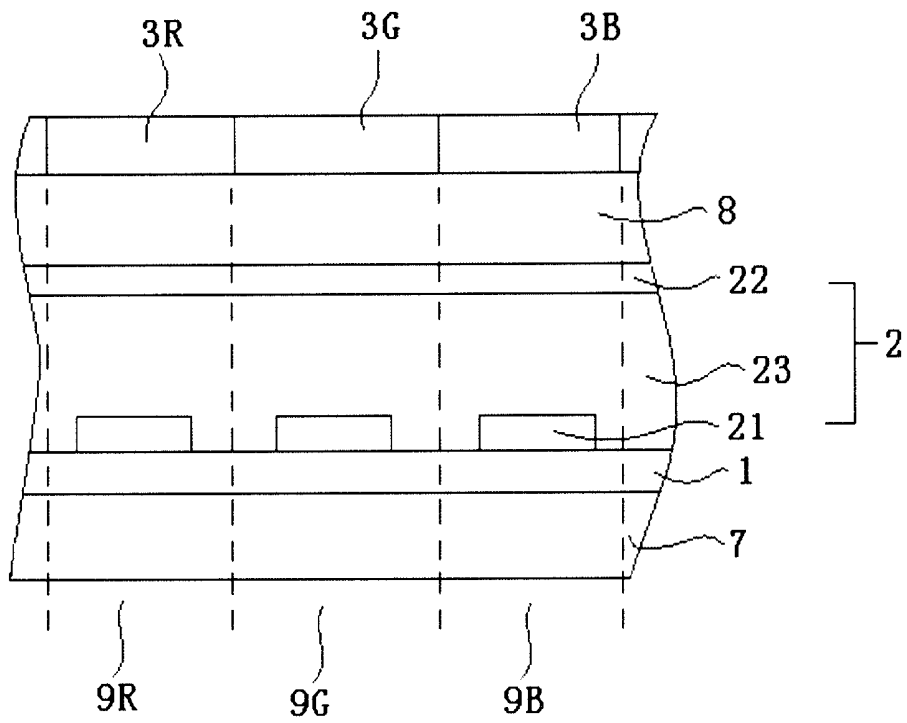

Figure 1

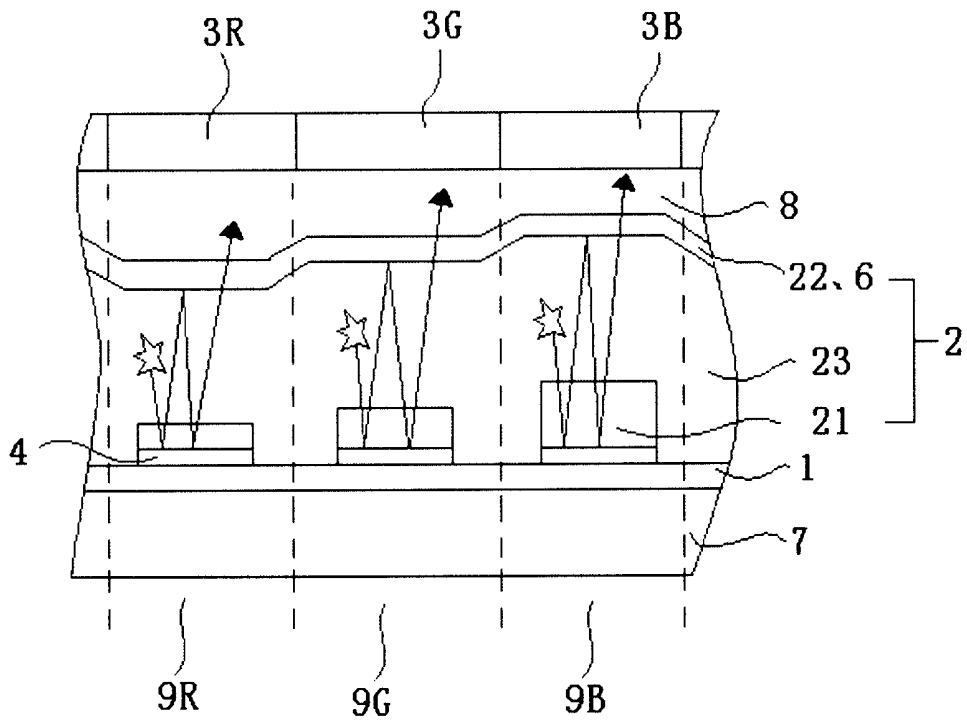

Figure 2

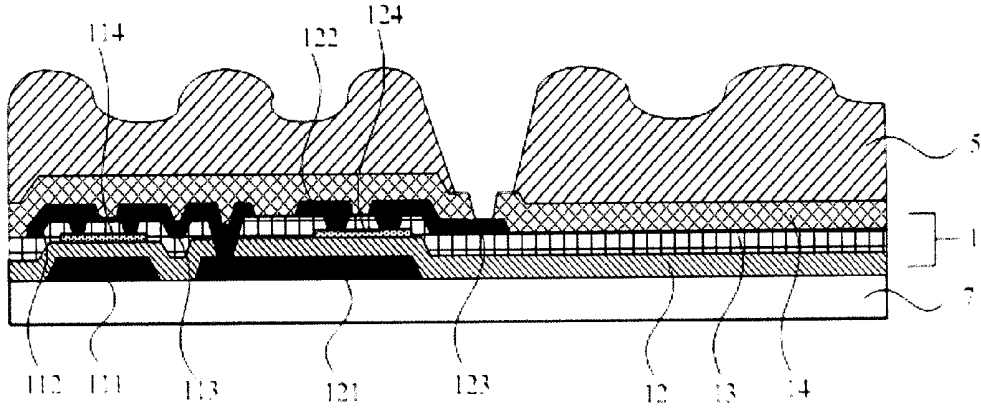

Figure 6

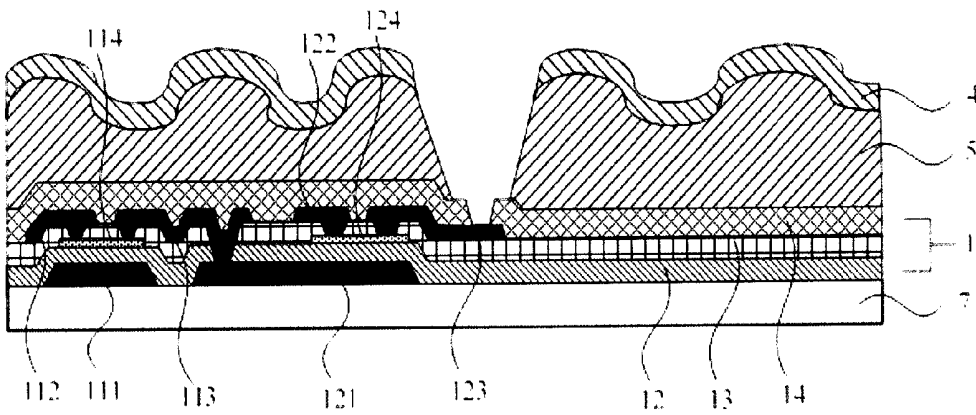

Figure 7

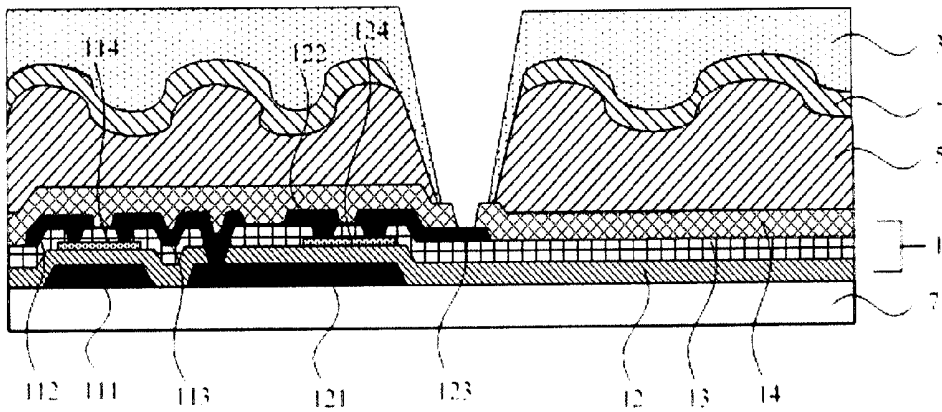

Figure 8

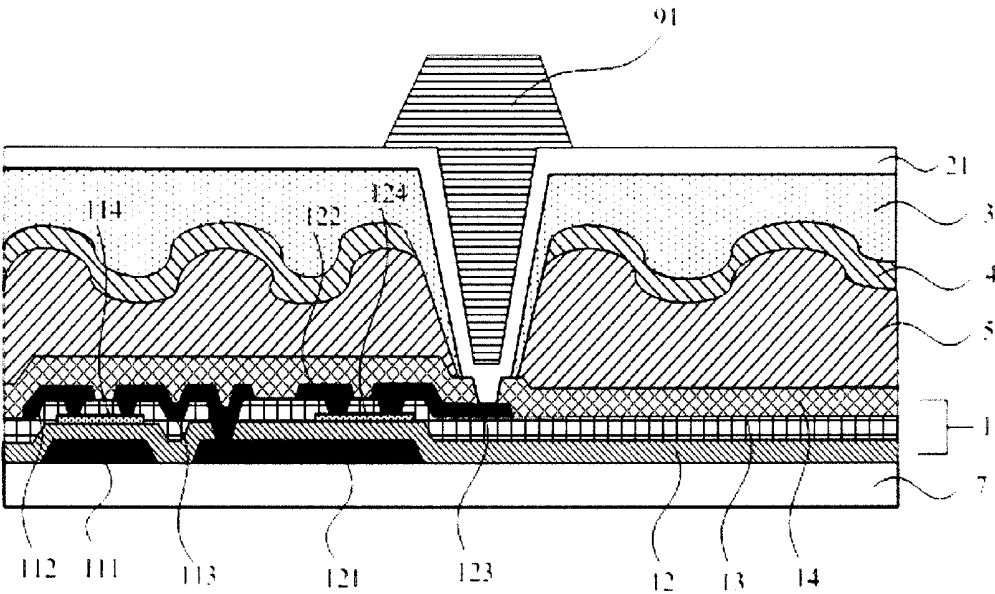

Figure 9

ARRAY SUBSTRATE, METHOD FOR FABRICATING THE SAME, AND OLED DISPLAY DEVICE

FIELD OF THE INVENTION

[0001] The present invention relates to the field of OLED display technology, more particularly, to an array substrate, a method for fabricating the same and an OLED display device.

BACKGROUND OF THE INVENTION

[0002] An Organic Light Emitting Diode (OLED) is an organic thin film electroluminescent (EL) device, which has advantages of simple fabrication process, low cost, high luminous efficiency and easy formation of flexible structure. Therefore, display technology employing an OLED has become important display technology.

[0003] An OLED display device comprises a plurality of pixel units, each of which has an OLED disposed therein. The luminous intensity of each OLED is controlled by controlling current flowing through the OLED, thereby realizing image display. Herein, each visible pixel on a display is made of a plurality of adjacent pixel units emitting light of different colors, and light emitted from the respective pixel units is mixed to form light emitted from the visible pixel. Colors (that is, colors of the corresponding color filter films) of the pixel units constituting the visible pixel may be selected in different modes, such as the RGB (red, green, blue) mode (that is, a red pixel unit, a green pixel unit, and a blue pixel unit form a visible pixel unit), the RGBW (red, green, blue, white) mode and the RGBY (red, green, blue, yellow) and the like.

[0004] As technologies of white OLEDs (WOLEDs) are well developed and WOLEDs have high luminous efficiency, the OLEDs are widely used in OLED display devices.

[0005] As illustrated in FIG. 1, a visible pixel unit of a WOLED display device may comprise three pixel units 9R, 9G and 9B of red, green, and blue (Of course, other modes are also applicable) disposed on a substrate 7, each pixel unit 9R, 9G or 9B has a Thin Film Transistor (TFT) drive layer 1 disposed therein, and an anode (a first electrode 21), a light emitting layer 23, a cathode (a second electrode 22), an encapsulation layer 8, and a color filter film 3R, 3G, or 3B (also referred to as a color filter plate) with a corresponding color are sequentially disposed on the TFT drive layer 1. The anode, the light emitting layer 23 and the cathode form an OLED 2. The TFT drive layer 1 may drive the anodes of the respective pixel units 9R, 9G and 9B independently, such that the respective OLEDs 2 emit light with different brightness, which becomes light of different colors after passing through corresponding color filter films 3R, 3G and 3B and is then mixed to form light emitted from the visible pixel.

[0006] To improve luminous efficiency, a microcavity structure may be formed in an OLED display device. The microcavity structure is a structure with a thickness in micron dimension formed between a reflection layer and a transmissive layer and light is continuously reflected between the two layers. Due to the resonance effect, light with specific wavelength in the light eventually emitted from the transmissive layer is enhanced, and the wavelength of the enhanced light depends on the thickness of the microcavity structure.

[0007] In a WOLED display device, different pixel units are used to emit light of different colors. Therefore, microcavity structures at different pixel units should enhance light with different wavelengths (light having the same color as the

color filter film), that is, the microcavity structures at different pixel units are of different thicknesses. To achieve this, as illustrated in FIG. 2, in the WOLED display device, the cathode is set as a transmissive layer 6, the anode is set as a transparent layer, and a reflection layer 4 is further disposed below the anode. As such, the thicknesses of the microcavity structures of the corresponding pixel units 9R, 9G and 9B may be controlled by adjusting the thicknesses of respective anodes.

[0008] However, the inventors find that at least the following problem exists in the prior art: the respective anodes of the array substrate are disposed in the same layer and may be originally formed in a single patterning process at the same time. However, in a WOLED display device having microcavity structures, the anodes of respective pixel units are of different thicknesses, and therefore they are separately formed in a plurality of patterning processes, or a dual-tone mask needs to be used in the patterning process, while these methods lead to complicated fabrication process and high cost.

SUMMARY OF THE INVENTION

[0009] Technical problems to be solved by the present invention include: providing an array substrate with simple fabrication process, low cost and high luminous efficiency, in view of the problem that array substrates with microcavity structures have complicated fabrication process and high cost in the prior art.

[0010] A technical solution used to solve the technical problems of the present invention is an array substrate, which comprises a plurality of pixel units disposed on a substrate, each pixel unit comprises: a TFT drive layer; an OLED further away from the substrate than the TFT drive layer and driven by it, the OLED sequentially comprises a first electrode, a light emitting layer, a second electrode in a direction further away from the substrate, wherein the first electrode is transparent, and the second electrode is a transmissive layer, or the second electrode is transparent and has a transmissive layer disposed thereon; a reflection layer disposed between the TFT drive layer and the OLED and forming a microcavity structure with the transmissive layer, and a reflective surface of the reflection layer has a concave-convex or corrugated structure thereon for causing diffuse reflection of light; and a color filter film disposed between the reflection layer and the OLED and located in the microcavity structure.

[0011] Herein, the TFT drive layer is a TFT array structure for driving the OLED and comprises a multi-layer structure including a TFT, a scan line, a data line, a supply voltage line, an insulating layer, a passivation layer etc. An OLED refers to as a structure capable of emitting light which comprises a first electrode, a second electrode and a light emitting layer sandwiched therebetween. In some regions on the substrate (such as those between respective pixel units), there may be only the second electrode and the light emitting layer but without the first electrode (therefore, the first electrodes in respective pixel units are separated from each other). Alternatively, an insulating pixel defining layer may be disposed between the first or the second electrode and the light emitting layer, such regions cannot emit light and thus not OLED is formed in these regions. Therefore, the reflection layer and the color filter film are only disposed at regions opposite to the OLEDs and not disposed at regions where the OLEDs are not formed. The light emitting layer refers to as a structure that may emit light under the action of current and may be a single-layer or

multi-layer structure. The light emitting layer comprises at least one organic electroluminescent material layer (EML), but it may also comprise an Electron transport layer (ETL) and an Electron injection layer (EIL) between the organic EML and the cathode layer, a Hole injection layer (HIL) and a Hole transport layer (HTL) between the organic EML and the anode layer, and other structures. The 'concave-convex or corrugated structure' refers to as a structure whose reflective surface has different heights at different locations in the thickness direction of the reflection layer so as to cause diffuse reflection of light incident on the reflective surface. Specifically, it may be convex dots or concave dots distributed on the reflective surface as a grid, or a strip-shaped corrugated structure, as long as the reflective surface has ups and downs.

[0012] In the array substrate of the present invention, the color filter film is disposed between the reflection layer and the OLED, and the microcavity structure is formed between the second electrode (or the transfective layer on the second electrode) and the reflection layer. Therefore, the color filter film is disposed in the microcavity structure, and the thickness of the microcavity structure can thus be adjusted by controlling the thickness of the color filter film. As the color filter films for different colors of pixel units are supposed to be formed in different steps, their thicknesses can be easily controlled respectively. Therefore, the method for fabricating an array substrate of the present invention is simple and of low cost in comparison with a conventional method for fabricating an array substrate with microcavity structures of different thicknesses formed in multiple patterning processes. Meanwhile, with the concave-convex or corrugated structure on the reflection layer, diffuse reflection of light occurs in the microcavity structure, increasing total amount of emitted light and improving luminous efficiency, and research shows that luminous efficiency may be improved by 50% with such a structure. Moreover, as the reflection layer and the OLED are disposed above the TFT drive layer, on one hand a location where the TFT is located may also be used to emit light, which results in high aperture ratio and high luminous efficiency, and on the other hand, the reflection layer may prevent the light from being incident on the TFT, thereby reducing leakage current of the TFT, leading to more precise display.

[0013] Preferably, the light emitting layer is a layer used for emitting white light.

[0014] Further preferably, the layer used for emitting white light comprises overlapping organic electroluminescent material layers emitting red light, green light and blue light, respectively; or is an organic electroluminescent material layer formed by mixing organic electroluminescent materials emitting red light, green light and blue light, respectively.

[0015] That is to say, the light emitting layer may emit white light in various ways. For example, the organic EL material layers respectively emitting red light, green light and blue light (of course, combination of other colors may also be used) may be overlapped, such that light emitted by the organic electroluminescent material layers is mixed to form white light. Alternatively, organic electroluminescent materials respectively emitting red light, green light and blue light may be mixed to form an organic electroluminescent material layer to emit white light.

[0016] Preferably, the TFT drive layer comprises a scan line, a data line, a supply voltage line, and a plurality sets of TFTs, each set of TFTs are used to drive the OLED in a pixel unit; wherein each set of TFTs comprise a switch TFT and a drive TFT, as for the switch TFT, a gate electrode thereof is

connected to the scan line, a source electrode thereof is connected to the data line, and a drain electrode is connected to a gate electrode of the drive TFT, and as for the drive TFT, a source electrode thereof is connected to the supply voltage line, and a drain electrode thereof is connected to the first electrode of the OLED.

[0017] Further preferably, the array substrate further comprises a resin layer disposed between the reflection layer and the TFT drive layer, and a surface of the resin layer that contacts the reflection layer has a concave-convex or corrugated structure disposed thereon.

[0018] As the reflection layer is generally made of metal material and has no fluidity, its surface morphology may vary with morphology of its underlying structure. Therefore, by disposing the concave-convex or corrugated structure on the resin layer, a corresponding concave-convex or corrugated structure is naturally formed on the reflection layer.

[0019] Preferably, a via is disposed in the color filter film and the resin layer, the first electrode is electrically connected to the TFT drive layer through the via, and an insulating pixel defining layer between the first electrode and the light emitting layer is disposed at the via.

[0020] Preferably, a thickness of the resin layer is in the range of 1000 to 30000 Å.

[0021] Preferably, the reflection layer is made of any metal from silver, aluminum, molybdenum, copper, titanium and chrome or an alloy of any two or more metals therefrom, and has a reflectivity of 80% to 100% and a thickness of 100 to 10000 Å.

[0022] Preferably, the transfective layer is made of any metal from silver, aluminum, molybdenum, copper, titanium and chrome or an alloy of any two or more metals therefrom, and has a transmissivity of 5% to 95% and a thickness of 10 to 200 Å.

[0023] Preferably, a thickness of the color filter film is in the range of 5000~40000 Å.

[0024] Preferably, the color filter film comprises a red filter film, a green filter film and a blue filter film; or a red filter film, a green filter film, a blue filter film and a white filter film; or a red filter film, a green filter film, a blue filter film and a yellow filter film.

[0025] That is to say, the color filter films in respective pixel units forming one visible pixel may have the above different color modes. Of course, other color modes can also be employed.

[0026] Preferably, the first electrode is a cathode of the OLED, the second electrode is an anode of the OLED; or the first electrode is an anode of the OLED, the second electrode is a cathode of the OLED.

[0027] Technical problems to be solved by the present invention include: providing a method for fabricating an array substrate with simple fabrication process, low cost and high luminous efficiency, in view of the problem that array substrates with microcavity structures are of complicated fabrication process and high cost in the prior art.

[0028] A technical solution used to solve the technical problems of the present invention is to provide a method for fabricating an array substrate, which comprises: forming a pattern comprising a TFT drive layer on a substrate; forming a pattern of a resin layer on the substrate subjected to the previous step, and forming a concave-convex or corrugated structure on the resin layer; forming a pattern comprising a reflection layer on the substrate subjected to the previous step, an upper surface of the reflection layer having a concave-

convex or corrugated structure thereon for causing diffuse reflection of light; forming a pattern comprising a color filter film on the substrate subjected to the previous step; forming a pattern comprising an OLED on the substrate subjected to the previous step such that when the reflection layer is opposite to the OLED, the color filter film is disposed between the reflection layer and the OLED; wherein a first electrode of the OLED that is closer to the substrate is transparent, a second electrode of the OLED that is further from the substrate is a transmissive layer, or an electrode of the OLED that is further from the substrate is transparent and has a transmissive layer disposed thereon.

[0029] Herein, a layer or a structure may be formed in various ways. For example, a whole film layer may be formed by means of coating, printing, deposition (sputtering, evaporation, chemical Vapor Deposition or the like); or, a desired pattern may also be directly formed through printing, controlled deposition and so on; or a desired pattern may also be formed through a patterning process, wherein a patterning process generally comprises forming a whole film layer, photoresist application, exposing, developing, etching, photoresist removal and other steps.

[0030] In an array substrate fabricated according to the method of the present invention, the color filter film is disposed in the microcavity structure; therefore thickness of the microcavity structure may be adjusted by controlling thickness of each color filter film when forming color filter films of different colors, without adding any new step. Therefore, the fabrication process is simple and of low cost. Moreover, as the concave-convex or corrugated structure exists in the microcavity structure, the luminous efficiency of the array substrate is high.

[0031] Preferably, forming a concave-convex or corrugated structure on the resin layer comprises forming the concave-convex or corrugated structure on the resin layer through a printing process or a patterning process using a dual-tone mask.

[0032] Herein, a patterning process using a dual-tone mask generally refers to a process in which a dual-tone mask (comprising a half-tone mask and a gray-tone mask) is used to control exposure amount of the photoresist at different locations, such that a part of the photoresist is exposed partially, and therefore the underlying layer is partially etched in the following etching step, thereby generating the concave-convex or corrugated structure.

[0033] Preferably, the pattern of the resin layer comprises a first via connected to the TFT drive layer, the pattern of the color filter film comprises a second via connected to the first via in the resin layer; and forming the pattern comprising the OLED on the substrate comprises: forming a pattern of the transparent first electrode through a patterning process, the first electrode being electrically connected to the TFT drive layer through the first via and the second via; forming a pattern of an insulating pixel defining layer formed at least above the first via and the second via through a patterning process; forming a light emitting layer on the substrate subjected to the previous step; and forming a transmissive second electrode on the substrate subjected to the previous step, or, forming a transparent second electrode on the substrate subjected to the previous step and forming a transmissive layer on the second electrode.

[0034] Technical problems to be solved by the present invention include: providing an OLED display device with simple fabrication process, low cost and high luminous effi-

ciency, in view of the problem that array substrates with microcavity structures are of complicated fabrication process and high cost in the prior art.

[0035] A technical solution used to solve the technical problems of the present invention is to provide an OLED display device, which includes the above array substrate.

[0036] The OLED display device of the present invention comprises the above array substrate, and therefore is of simple fabrication process, low cost and high luminous efficiency.

[0037] The present invention is especially suitable for a WOLED display device.

BRIEF DESCRIPTION OF THE DRAWINGS

[0038] FIG. 1 is a schematic diagram illustrating a cross-sectional structure of a part of an existing array substrate;

[0039] FIG. 2 is a schematic diagram illustrating a cross-sectional structure of a part of an existing array substrate having a microcavity structure;

[0040] FIG. 3 is a schematic diagram illustrating a cross-sectional structure of a part of an array substrate of Embodiment 2 of the present invention;

[0041] FIG. 4 is an equivalent circuit diagram of an OLED drive circuit of the array substrate of Embodiment 2 of the present invention;

[0042] FIG. 5 is a schematic diagram illustrating a cross-sectional structure of a part of an array substrate after forming a TFT drive layer in a method for fabricating an array substrate of Embodiment 4 of the present invention;

[0043] FIG. 6 is a schematic diagram illustrating a cross-sectional structure of a part of an array substrate after forming a resin layer in the method for fabricating an array substrate of Embodiment 4 of the present invention;

[0044] FIG. 7 is a schematic diagram illustrating a cross-sectional structure of a part of an array substrate after forming a reflection layer in the method for fabricating an array substrate of Embodiment 4 of the present invention;

[0045] FIG. 8 is a schematic diagram illustrating a cross-sectional structure of a part of an array substrate after a forming color filter film in the method for fabricating an array substrate of Embodiment 4 of the present invention; and

[0046] FIG. 9 is a schematic diagram illustrating a cross-sectional structure of a part of an array substrate after forming a pixel defining layer in the method for fabricating an array substrate of Embodiment 4 of the present invention.

DESCRIPTION OF REFERENCE NUMERALS

[0047] 1. TFT drive layer; 10. drive TFT; 11. switch TFT; 111. gate electrode of the switch TFT; 112. source electrode of the switch TFT; 113. drain electrode of the switch TFT; 114. active region of the switch TFT; 121. gate electrode of the drive TFT; 122. source electrode of the drive TFT; 123. drain electrode of the drive TFT; 124. active region of the drive TFT; 12. gate insulating layer; 13. spacer insulating layer; 14. passivation layer; 2. OLED; 21. first electrode; 22. second electrode; 23. light emitting layer; 3. color filter film; 3R. red filter film; 3G. green filter film; 3B. blue filter film; 4. reflection layer; 5 resin layer; 6. transmissive layer; 7. substrate; 8. encapsulation layer; 9R. red pixel unit; 9G. green pixel unit; 9B. blue pixel unit; 91. pixel defining layer; DATA. data line; SCAN. scan line; Vdd. supply voltage line; Cs. storage capacitor.

DETAILED DESCRIPTION OF EMBODIMENTS

[0048] In the following, the present invention will be described in details in conjunction with the drawings and implementations, such that the person skilled in the art can better understand the technical solutions of the present invention.

Embodiment 1

[0049] The present embodiment provides an array substrate, which comprises a plurality of pixel units disposed on a substrate; and each pixel unit comprises:

[0050] a TFT drive layer;

[0051] an OLED further away from the substrate than the TFT drive layer and driven by it, the OLED sequentially comprises a first electrode, a light emitting layer, a second electrode in a direction further away from the substrate, wherein the first electrode is transparent, the second electrode is a transfective layer, or the second electrode is transparent and has a transfective layer disposed thereon;

[0052] a reflection layer, which is disposed between the TFT drive layer and the OLED and forms a microcavity structure with the transfective layer, and a reflective surface of the reflection layer has a concave-convex or corrugated structure disposed thereon for causing diffuse reflection of light; and

[0053] a color filter film disposed between the reflection layer and the OLED and located in the microcavity structure.

[0054] In the array substrate of the present embodiment, the color filter film is disposed between the reflection layer and the OLED, and the microcavity structure is formed between the second electrode (or the transfective layer on the second electrode) and the reflection layer. Therefore, the color filter film is disposed in the microcavity structure, and thickness of the microcavity structure can thus be adjusted by controlling thicknesses of the color filter film. As color filter films for pixel units of different colors are supposed to be formed in different steps, their thickness can be easily controlled respectively. Therefore, the method for fabricating an array substrate of the present invention is simple and of low cost. Meanwhile, with the concave-convex or corrugated structure on the reflection layer, diffuse reflection of light occurs in the microcavity structure, increasing total amount of emitted light and improving the luminous efficiency, and research shows that the luminous efficiency may be improved by 50% with such a structure. Moreover, as the reflection layer and the OLED are disposed above the TFT drive layer, on one hand a location where the TFT is located may also be used to emit light, which results in high aperture ratio and high luminous efficiency, and on the other hand, the reflection layer may prevent the light from being incident on the TFT, thereby reducing leakage current of the TFT, leading to precise display.

Embodiment 2

[0055] As illustrated in FIGS. 3 and 4, the present embodiment provides an array substrate, which comprises a plurality of pixel units on a substrate 7, wherein a plurality of adjacent pixel units having color filter films of different colors forms one 'visible pixel' on a display. Herein a color filter film 3 may have various color modes. Preferably, the color filter film 3 comprises a red filter film, a green filter film, a blue filter film (the RGB mode). Alternatively, the color filter film 3 comprises a red filter film, a green filter film, a blue filter film and

a white filter film (the RGBW mode). Alternatively, the color filter film 3 comprises a red filter film, a green filter film, a blue filter film and a yellow filter substrate (the RGBY mode).

[0056] As illustrate in FIG. 3, the array substrate sequentially comprises a TFT drive layer 1, a resin layer 5, a reflection layer 5, a color filter film 3, an OLED 2 and an encapsulation layer in a direction further away from the substrate.

[0057] The TFT drive layer 1 is a TFT array used for driving the OLED 2, and mainly comprises a TFT, a scan line SCAN, a data line DATA, a supply voltage line Vdd, a gate insulating layer 12, a spacer insulating layer 13, a passivation layer 14 and other structures.

[0058] Herein, each TFT is preferably a metal oxide TFT, such as a Zinc tin oxide (ZnSnO) TFT, an Indium gallium zinc oxide (IGZO) TFT or the like, as a metal oxide TFT has advantages of simple structure, easy fabrication, high migration ratio, excellent uniformity and so on. Of course, an amorphous silicon TFT, an organic TFT etc. can also be feasible.

[0059] Preferably, a structure of the TFT drive layer 1 is illustrated in FIG. 3, and the TFT drive layer 1 comprises a plurality sets of TFTs, each set of TFTs are adapted for controlling a pixel unit. Moreover, each set of TFTs comprise a switch TFT 11 and a drive TFT 10, both of which respectively have active regions 114 and 124 independent from each other. As for the switch TFT 11, the gate electrode 111 is connected to the scan line SCAN, the source electrode 112 is connected to the data line DATA, the drain electrode 113 is connected to the gate electrode 121 of the drive TFT 10, and as for the drive TFT 10, the source electrode 122 is connected to the supply voltage line Vdd and forms a storage capacitor Cs with the drain electrode 113 of the switch TFT 11, the drain electrode 123 is connected to a first electrode 21 (i.e., anode) of the OLED 2, thereby forming an equivalent circuit as shown in FIG. 4. Herein respective structures of the TFT drive layer 1 are separated from each other by the gate insulating layer 12 and the spacer insulating layer 13, and the TFTs are separated from other structures in the array substrate by the passivation layer 14.

[0060] Of course, what is described above is just a specific structure of the TFT drive layer 1, which may have other structures, as long as it may drive the OLEDs 2 in respective pixel units independently. As the TFT drive layer 1 may employ various known forms, it will not be elaborated here.

[0061] Preferably, a resin layer 5 is disposed above the passivation layer 14 of the TFT drive layer 1, an upper surface of the resin layer 5 has the concave-convex or corrugated structure disposed thereon, and the resin layer 5 preferably has a thickness in the range of 1000 to 30000 Å.

[0062] A reflection layer 4 is disposed on the resin layer 5, and on an upper surface of the reflection layer 4, a concave-convex or corrugated structure corresponding to the concave-convex or corrugated structure on the resin layer 5 is naturally formed. The concave-convex or corrugated structure may cause diffuse reflection of light incident thereon, thereby further improving the luminous efficiency. Analysis shows that the luminous efficiency may be improved by about 50% in comparison with an array substrate without the concave-convex or corrugated structure.

[0063] Herein, the concave-convex or corrugated structure can be easily realized on the resin layer 5, and therefore, the concave-convex or corrugated structure on the reflection layer 4 may be easily formed through disposing the resin layer 5. Of course, the concave-convex or corrugated structure on the reflection layer 4 can also be realized in other ways. For

example, the concave-convex or corrugated structure may be formed on the passivation layer **14** of the TFT drive layer **1** without disposing the resin layer **5**, thereby forming the corresponding concave-convex or corrugated structure on the reflection layer **4**. Alternatively, the concave-convex or corrugated structure may be formed on the reflection layer **4** directly.

[0064] Preferably, the reflection layer **4** is made of any metal from silver, aluminum, molybdenum, copper, titanium and chrome or an alloy of two or more metals therefrom, and has a reflectivity of 80% to 100% and a thickness of 100 to 10000 Å.

[0065] The color filter film **3** is disposed on the reflection layer **4** and used for filtering light passing therethrough. The color filter films in respective pixel units are of different colors, thereby causing the respective pixel units to emit light of different colors. As the color filter film **3** has a relatively large thickness and has fluidity before being cured, its upper surface is generally planar. Of course, it is also feasible to form the concave-convex or corrugated structure on the color filter film **3**.

[0066] Preferably, a thickness of the color filter film is in the range of 5000~40000 Å. Since the color filter film **3** is disposed in the microcavity structure, a range of the thickness of the color filter film **3** is relatively large. Thus, thickness of the microcavity structure may be controlled by adjusting thickness of the color filter film **3**, such that the microcavity structure in each pixel unit may intensify light having the same color as the color filter film.

[0067] The OLED **2** is disposed on the color filter film **3**, and the OLED **2** sequentially comprises a transparent first electrode **21** (i.e., anode), a light emitting layer **23**, a second electrode **22** (i.e., cathode) in a direction away from the substrate **7**, wherein, the second electrode **22** is a transmissive layer **6**, and the first electrode **21** is made of a transparent conductive material such as indium tin oxide (ITO), indium zinc oxide (IZO) or the like.

[0068] In the array substrate of this embodiment, the transmissive layer **6** (the second electrode **22**) and the reflection layer **4** form the microcavity structure. Light emitted from the light emitting layer **23** may be reflected between the two layers for multiple times before emitted outside from the transmissive layer **6**. Moreover, Due to the resonance effect, light with a specific wavelength (light having the same color as the color filter film of the pixel unit) is intensified, thereby improving the luminous efficiency.

[0069] Alternatively, the second electrode **22** may be configured to be transparent (for example, the second electrode **22** is made of a transparent material such as ITO), and then a separate transmissive layer **6** is disposed on the second electrode **22**, which may also form the above microcavity structure, and is not elaborated here.

[0070] Obviously, although the first electrode **21** in this embodiment is the anode of the OLED **2** and the second electrode **22** is the cathode of the OLED **2**, it is also feasible that the first electrode **21** is the cathode of the OLED **2** and the second electrode **22** is the anode of the OLED **2**.

[0071] Preferably, the transmissive layer **6** (the second electrode **22** or the separate transmissive layer **6**) is made of any metal from silver, aluminum, molybdenum, copper, titanium and chrome or an alloy of two or more metals therefrom, and has a transmissivity of 5% to 95% and a thickness of 10 to 200 Å.

[0072] Preferably, the light emitting layer **23** is a light emitting layer for emitting white light, which may be realized in various ways. Further preferably, the light emitting layer for emitting white light comprises overlapping organic electroluminescent material layers for emitting red light, green light and blue light, respectively; or is an organic electroluminescent material layer formed by mixing organic electroluminescent materials emitting red light, green light and blue light, respectively.

[0073] As WOLED technology is relatively mature, and white light, after passing a color filter film, may directly become light of the same color as the color filter film, display is easily realized with the light emitting layer **23** emitting white light. Of course, it is also feasible that the light emitting layer **23** may emit light with a color, as long as colors of the color filter films are changed accordingly to ensure that display can be eventually realized.

[0074] Preferably, the first electrode **21** may be electrically connected to the drain electrode **123** of the drive TFT **10** in the TFT drive layer **1** through the first via in the color filter film **3** and the resin layer **5** (of course, a corresponding opening should also be disposed in the reflection layer **4** and the passivation layer **14** of the TFT drive layer **1**). Meanwhile, an insulating pixel defining layer (PDL) **91** between the first electrode **21** and the light emitting layer **23** is disposed at the via.

[0075] In this embodiment, the color filter film **3** and the resin layer **5** are disposed between the OLED **2** and the TFT drive layer **1**, and therefore the first electrode **21** needs to be electrically connected to the TFT drive layer **1** through the first via. Meanwhile, as the color filter film **3** and the reflection layer **4** are not disposed at the first via, the light emitting layer **23** at this position is not supposed to emit light (or no OLED **2** is formed at this position), thus it is required to dispose the insulating PDL **91** to block current between the first electrode **21** and the light emitting layer **23** at this position. Of course, the PDL **91** may be in other forms, such as being disposed between the second electrode **22** and the light emitting layer **23**, as long as the PDL **91** may function as preventing the OLED **2** from emitting light (in other words, as long as it may function as defining the display region of the pixel unit).

[0076] Of course, the first electrode **21** may also be electrically connected to the TFT drive layer **1** by other ways, such as by locations between respective pixel units.

[0077] Of course, the array substrate of the present invention may also have other conventional structures, for example, the PDL **91** may also be disposed at edges of respective pixel units.

Embodiment 3

[0078] The present embodiment provides a method for fabricating an array substrate, which comprises the following steps:

[0079] forming a pattern comprising a TFT drive layer on a substrate;

[0080] forming a pattern of a resin layer on the substrate subjected to the previous step, and forming a concave-convex or corrugated structure on the resin layer;

[0081] forming a pattern comprising a reflection layer on the substrate subjected to the previous step, an upper surface of the reflection layer having a concave-convex or corrugated structure for causing diffuse reflection of light disposed thereon, which is corresponding to the concave-convex or corrugated structure on the resin layer;

[0082] forming a pattern comprising a color filter film on the substrate subjected to the previous step;

[0083] forming a pattern comprising an OLED on the substrate subjected to the previous step, such that the reflection layer is opposite to the OLED, and the color filter film is disposed between the reflection layer and the OLED; wherein a first electrode of the OLED that is closer to the substrate is transparent, a second electrode of the OLED that is further from the substrate is a transfective layer, or a second electrode of the OLED that is further from the substrate is transparent and has a transfective layer disposed thereon.

[0084] In an array substrate fabricated according to the method of the present invention, the color filter film is disposed in the microcavity structure, and therefore thickness of the microcavity structure may be adjusted by respectively controlling thickness of respective color filter films of different colors when forming the color filter films, without adding any new step. Therefore, the fabrication process is simple and of low cost. Moreover, as the concave-convex or corrugated structure exists in the microcavity structure, the luminous efficiency of the array substrate is high.

Embodiment 4

[0085] The present embodiment provides a method for fabricating an array substrate, as illustrated in FIGS. 5 to 9, the method comprises the following steps:

[0086] S01. forming a pattern of a TFT drive layer 1 on a substrate 7, obtaining a structure as illustrated in FIG. 5. Herein the TFT drive layer 1 comprises a structure with a plurality of layers, which may be sequentially formed in multiple patterning processes. Generally, a patterning process comprises: first forming a whole film layer with a specific material (e.g., by means of deposition, coating, sputtering etc.), and then removing a part of the whole film layer through a photolithography process (generally comprising photoresist application, exposing, developing, etching, photoresist removal and other steps), such that the remaining part forms the desired pattern. A patterning process is a known process and the structure of the TFT drive layer 1 may be the same as that in the prior art, and therefore detail formation procedure thereof will not be described in details here.

[0087] S02. forming a resin layer 5, forming a concave-convex or corrugated structure on the resin layer 5 by printing or by a patterning process using a dual-tone mask, and forming a first via connected to the TFT drive layer 1 in the resin layer 5 through a patterning process (it may be a separate patterning process or the patterning process for forming the concave-convex or corrugated structure), so as to obtain a structure as illustrated in FIG. 6. Herein a patterning process using a dual-tone mask generally refers to as a process in which a dual-tone mask (comprising a half-tone mask and a gray-tone mask) is used to control exposure amount of photoresist at different locations, such that a part of photoresist is exposed partially, and therefore, the underlying layer is partially etched in the following etching step, thereby generating the concave-convex or corrugated structure. Of course, the resin layer 5 may also be formed of photosensitive resin material, and by this means, the structure illustrated in FIG. 6 may be obtained by directly performing exposing and developing in the patterning process, without performing any process related to photoresist.

[0088] S03. forming a pattern of the reflection layer 4 as illustrated in FIG. 7 through a patterning process. As the concave-convex or corrugated structure exists on the resin

layer 5, the concave-convex or corrugated structure corresponding to the concave-convex or corrugated structure on the resin layer 5 is naturally formed on the reflection layer 4. The concave-convex or corrugated structure may cause diffuse reflection of light incident thereon.

[0089] S04. respectively forming color filter films with the required colors in respective pixel units through printing or through a patterning process, so as to obtain a pattern of the color filter film 3 illustrated in FIG. 8. Herein the color filter film 3 has a second via connected to the first via in the resin layer 5 (that is, the formed vias, as a whole, are connected to the TFT drive layer 1).

[0090] S05. forming a pattern comprising an OLED 2, which comprises:

[0091] S051. forming a pattern of a transparent first electrode 21 through a patterning process, the first electrode 21 being electrically connected to the TFT drive layer 1 through the first via and the second via;

[0092] S052. forming a pattern of an insulating pixel defining layer 91 formed at least above the first via and the second via through a patterning process, so as to obtain the structure illustrated in FIG. 9;

[0093] S053. forming a light emitting layer 23;

[0094] S054. forming a transfective second electrode 22; alternatively, this step may include first forming a transparent second electrode 22 and then forming a transfective layer 6 on the second electrode 22; and

[0095] S06. forming an encapsulation layer 8, so as to obtain the array substrate illustrated in FIG. 3. At this point, the array substrate may function as an OLED display device, or packaging and other processes may be performed on the array substrate to obtain an OLED display device.

Embodiment 5

[0096] The present embodiment provides an OLED display device comprising the above array substrate. The display device may include an OLED panel, a mobile phone, a tablet PC, a television, a display, a notebook PC, a digital photo-frame, a navigator and any other product or device having a display function.

[0097] The OLED display device of this embodiment has the above array substrate, and therefore is of simple fabrication process, low cost and high luminous efficiency.

[0098] Of course, the OLED display device of this embodiment may have other conventional structures such as an enclosed substrate which is assembled with the array substrate to form a cell, a power unit, a display drive unit and the like.

[0099] It should be understood that, the above implementations are only exemplary embodiments used to explain the principle of the present invention. However, the present invention is not limited thereto. For a person skilled in the art, various variations and improvements can be made without departing from the spirit and substance of the present invention, and these variations and improvements are also deemed as the protection scope of the present invention.

1. An array substrate, comprising a plurality of pixel units disposed on a substrate, wherein each pixel unit comprises:

a TFT drive layer;

an OLED further away from the substrate than the TFT drive layer and driven by it, the OLED sequentially comprising a first electrode, a light emitting layer, and a second electrode in a direction away from the substrate, wherein the first electrode is transparent, and the second

electrode is a transfective layer, or the second electrode is transparent and has a transfective layer disposed thereon;

a reflection layer disposed between the TFT drive layer and the OLED and forming a microcavity structure with the transfective layer, and a reflective surface of the reflection layer having a concave-convex or corrugated structure thereon for causing diffuse reflection of light; and a color filter film disposed between the reflection layer and the OLED and located in the microcavity structure.

2. The array substrate of claim 1, wherein the light emitting layer is a light emitting layer used for emitting white light.

3. The array substrate of claim 2, wherein the light emitting layer used for emitting white light comprises:

overlapping organic electroluminescent material layers for emitting red light, green light and blue light, respectively;

or

an organic electroluminescent material layer formed by mixing organic electroluminescent materials emitting red light, green light and blue light, respectively.

4. The array substrate of claim 1, wherein,

the TFT drive layer comprises a scan line, a data line, a supply voltage line and a plurality sets of TFTs, each set of TFTs are used to drive the OLED in one pixel unit;

wherein each set of TFTs comprise a switch TFT and a drive TFT, as for the switch TFT, a gate electrode thereof is connected to the scan line, a source electrode thereof is connected to the data line, and a drain electrode thereof is connected to a gate electrode of the drive TFT, and as for the drive TFT, a source electrode thereof is connected to the supply voltage line, and a drain electrode thereof is connected to the first electrode of the OLED.

5. The array substrate of claim 1, further comprising a resin layer disposed between the reflection layer and the TFT drive layer, and a surface of the resin layer that contacts the reflection layer has a concave-convex or corrugated structure disposed thereon.

6. The array substrate of claim 2, further comprising a resin layer disposed between the reflection layer and the TFT drive layer, and a surface of the resin layer that contacts the reflection layer has a concave-convex or corrugated structure disposed thereon.

7. The array substrate of claim 3, further comprising a resin layer disposed between the reflection layer and the TFT drive layer, and a surface of the resin layer that contacts the reflection layer has a concave-convex or corrugated structure disposed thereon.

8. The array substrate of claim 5, wherein a via is disposed in the color filter film and the resin layer, the first electrode is electrically connected to the TFT drive layer through the via, and an insulating pixel defining layer between the first electrode and the light emitting layer is disposed at the via.

9. The array substrate of claim 5, wherein a thickness of the resin layer is in the range of 1000 to 30000 Å.

10. The array substrate of claim 1, wherein the reflection layer is made of any metal from silver, aluminum, molybdenum, copper, titanium and chrome or an alloy of any two or more metals therefrom, and has a reflectivity of 80% to 100% and a thickness of 100 to 10000 Å, and/or the transfective layer is made of any metal from silver, aluminum, molybdenum, copper, titanium and chrome or an alloy of any two or

more metals therefrom, and has a transmissivity of 5% to 95% and a thickness of 10 to 200 Å.

11. The array substrate of claim 2, wherein the reflection layer is made of any metal from silver, aluminum, molybdenum, copper, titanium and chrome or an alloy of any two or more metals therefrom, and has a reflectivity of 80% to 100% and a thickness of 100 to 10000 Å, and/or the transfective layer is made of any metal from silver, aluminum, molybdenum, copper, titanium and chrome or an alloy of any two or more metals therefrom, and has a transmissivity of 5% to 95% and a thickness of 10 to 200 Å.

12. The array substrate of claim 3, wherein the reflection layer is made of any metal from silver, aluminum, molybdenum, copper, titanium and chrome or an alloy of any two or more metals therefrom and has a reflectivity of 80% to 100% and a thickness of 100 to 10000 Å, and/or the transfective layer is made of any metal from silver, aluminum, molybdenum, copper, titanium and chrome or an alloy of any two or more metals therefrom, and has a transmissivity of 5% to 95% and a thickness of 10 to 200 Å.

13. The array substrate of claim 1, wherein a thickness of the color filter film is in the range of 5000~40000 Å.

14. The array substrate of claim 1, wherein the color filter film comprises:

a red filter film, a green filter film and a blue filter film; or a red filter film, a green filter film, a blue filter film and a white filter film; or

a red filter film, a green filter film, a blue filter film and a yellow filter film.

15. The array substrate of claim 1, wherein the first electrode is a cathode of the OLED, and the second electrode is an anode of the OLED; or

the first electrode is an anode of the OLED, and the second electrode is a cathode of the OLED.

16. The array substrate of claim 2, wherein the first electrode is a cathode of the OLED, and the second electrode is an anode of the OLED; or

the first electrode is an anode of the OLED, and the second electrode is a cathode of the OLED.

17. A method for fabricating an array substrate, comprising:

forming a pattern comprising a TFT drive layer on a substrate;

forming a pattern of a resin layer on the substrate subjected to the previous step, and

forming a concave-convex or corrugated structure on the resin layer;

forming a pattern comprising a reflection layer on the substrate subjected to the previous step, an upper surface of the reflection layer having a concave-convex or corrugated structure thereon for causing diffuse reflection of light;

forming a pattern comprising a color filter film on the substrate subjected to the previous step; and

forming a pattern comprising an OLED on the substrate subjected to the previous step, such that the reflection layer is opposite to the OLED and the color filter film is disposed between the reflection layer and the OLED; wherein a first electrode of the OLED that is closer to the substrate is transparent, a second electrode of the OLED that is further from the substrate is a transfective layer, or an electrode of the OLED that is further from the substrate is transparent and has a transfective layer disposed thereon.

18. The method for fabricating an array substrate of claim 17, wherein forming a concave-convex or corrugated structure on the resin layer comprises: forming the concave-convex or corrugated structure on the resin layer through a printing process or through a patterning process using a dual-tone mask.

19. The method for fabricating an array substrate of claim 17, wherein the pattern of the resin layer comprises a first via connected to the TFT drive layer, and the pattern of the color filter film comprises a second via connected to the first via in the resin layer; and

forming the pattern of the OLED on the substrate comprises:

- forming a pattern of the transparent first electrode through a patterning process, the first electrode being electrically connected to the TFT drive layer through the first via and the second via;
- forming a pattern of an insulating pixel defining layer, which is at least formed above the first via and the second via, through a patterning process,
- forming a light emitting layer on the substrate subjected to the previous step; and
- forming the transfective second electrode on the substrate subjected to the previous step, or, forming the

transparent second electrode on the substrate subjected to the previous step and forming the transfective layer on the second electrode.

20. An OLED display device, comprising an array substrate comprising a plurality of pixel units disposed on a substrate, wherein each pixel unit comprises:

a TFT drive layer;

an OLED further away from the substrate than the TFT drive layer and driven by it, the OLED sequentially comprising a first electrode, a light emitting layer, and a second electrode in a direction away from the substrate, wherein the first electrode is transparent, and the second electrode is a transfective layer, or the second electrode is transparent and has a transfective layer disposed thereon;

a reflection layer disposed between the TFT drive layer and the OLED and forming a microcavity structure with the transfective layer, and a reflective surface of the reflection layer having a concave-convex or corrugated structure thereon for causing diffuse reflection of light; and a color filter film disposed between the reflection layer and the OLED and located in the microcavity structure.

* * * * *

专利名称(译)	阵列基板，其制造方法以及OLED显示装置		
公开(公告)号	US20140159021A1	公开(公告)日	2014-06-12
申请号	US14/105141	申请日	2013-12-12
[标]申请(专利权)人(译)	京东方科技集团股份有限公司		
申请(专利权)人(译)	京东方科技集团股份有限公司.		
当前申请(专利权)人(译)	京东方科技集团股份有限公司.		
[标]发明人	SONG YOUNGSUK YOO SEONGYEOL CHOI SEUNGJIN KIM HEECHEOL		
发明人	SONG, YOUNGSUK YOO, SEONGYEOL CHOI, SEUNGJIN KIM, HEECHEOL		
IPC分类号	H01L27/32		
CPC分类号	H01L27/322 H01L27/3244 H01L51/5225 H01L51/5265		
优先权	201210536682.9 2012-12-12 CN		
其他公开文献	US9209231		
外部链接	Espacenet USPTO		

摘要(译)

本发明提供一种阵列基板，其制造方法以及OLED显示装置。阵列基板的每个像素单元包括：TFT驱动层；OLED比OLED驱动层更远离基板并由其驱动，OLED依次包括第一电极，发光层，第二电极，其中第一电极是透明的，第二电极是透反层，或者第二电极是透明的并且具有设置在其上的半透半反层；反射层设置在TFT驱动层和OLED之间，与半透半反射层形成微腔结构，反射层的反射表面上设置有凹凸或波纹结构，用于引起光的漫反射；滤色膜设置在反射层和OLED之间并位于微腔结构中。

